

Improve Performance and Reduce Maintenance Costs



Model Q45D

Dissolved Oxygen Monitor

Why Throw Away Money?

ATI's Model Q45D Dissolved Oxygen monitor is designed to provide reliable oxygen measurement and reduce maintenance costs. The galvanic dissolved oxygen sensor uses a rugged 5 mil Teflon membrane to resist mechanical abrasions and tears. The membrane serves as a barrier to allow molecular oxygen to diffuse into the reaction cell where it is reduced at the working electrode. This reaction produces a small current which is proportional to oxygen concentration.

In applications where process constituents adhere to the membrane, frequent membrane cleaning is required. To keep the dissolved oxygen system nearly maintenance free, an optional Auto-Cleaner can be included to remove those materials that build up on the sensor membrane. The cleaning cycle is user selectable to maximize the cleaning effectiveness.

When sensor maintenance is required, our cartridge-based sensor makes it fast and easy. Where other manufacturers make you throw away the cartridge, we've made our cartridge field-repairable. We also include enough replacement parts to rebuild your cartridge ten times. When you consider the average cost of a competitor's cartridge at \$125, ATI can save you thousands of dollars in maintenance costs.



Dissolved Oxygen Monitor



Auto-Clean Sensor

Monitor Features

Loop-powered, AC, or Battery Versions: This line of microprocessor based instrumentation allows for easy implementation of loop-powered, line-powered, or battery-powered capability within the same instrument. This instrument can be rapidly converted between any of these versions with no requirement for software change.

- Loop-powered (16-35 VDC) Transmitter, 4-20 mA output
- Line-powered (115/230 VAC) Analyzer, dual relays, dual 4-20 mA outputs
- Battery-powered (9 VDC) Monitor/Data Logger, dual 0-2.5 VDC outputs

Large, Dual Line Display: The large, high contrast, super-twist display provides excellent readability over a wide operating temperature range, even in low light conditions. The main display line consists of large, segmented

characters with measurement units. The secondary display line utilizes easily readable dot matrix characters for clear display of calibration and diagnostic messages. Two of four measured parameters may be displayed simultaneously.

Interactive User Interface: Four-button programming provides intuitive navigation through the menu driven user interface

Dual Alarm/Analog Outputs: AC operated systems provide two relays that are configurable for either "control mode" or "alarm mode" of operation.

Flexible Calibration: Air and sample calibration options include temperature, barometric pressure, and salinity compensation. All calibration methods include stability monitors to check temperature and main parameter stability before accepting data.

Clean Running Means Better Performance

It's a fact: A clean D.O. sensor performs better.

That's because when there's nothing between the sensing membrane and the water in the tank, you get uniform oxygen transfer for accurate measurement of dissolved oxygen content. And that translates into improved process performance, energy savings, and more effective water treatment.

Trouble is, not all D.O. monitors are easy to clean. Units that don't clean themselves need to be removed for frequent maintenance. And those that do clean themselves with grindstones or brushes can be expensive and difficult to maintain. Still others use chlorine gas to kill contaminants on the sensor's surface, but do nothing to remove contaminant buildup, leaving the source of the problem intact.

Enter ATI's Auto-Clean D.O. Monitor, the first D.O. monitor to clean itself with air. Biological growth and other contaminants are literally blasted from the Teflon membrane. The result: reduced maintenance, better performance, and more accurate D.O. monitoring.



The Auto-Clean DO Monitor

Keeping Clean Was Never So Simple

All dissolved oxygen sensors are affected by process coating. Any material that slows the diffusion of oxygen into the reaction cell will cause an error in the oxygen reading. If the system doesn't have a means to clean itself, the sensor will require frequent manual cleanings, which means higher maintenance costs.

Our self contained Auto-Clean system generates a series of high pressure air blasts to remove foulants from the face of the sensor. Each cleaning cycle lasts approximately 3 minutes, during which the monitor outputs are placed in a HOLD condition to prevent false readings or alarms. The user can vary the cleaning cycle frequency from as often as once every two hours, to as little as once a day.

ATI was the first to introduce a dissolved oxygen system that cleans itself with air. Others have tried to copy our system, but none are more effective at removing biological growth and other contaminants than the ATI Auto-Clean system.

So don't be fooled by imitation air pump cleaners that are minimally effective at cleaning your sensor. Trust the original Air-Blast system. Trust the best.

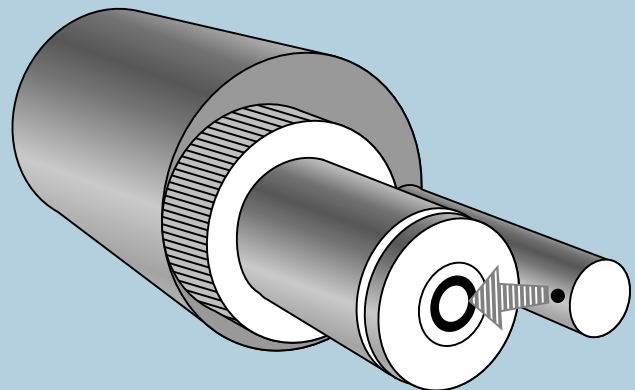

A blast of air keeps the Auto-Clean sensor clean.

Our Sensor Makes Sense.

The Auto-Clean sensor uses the same rebuildable cartridge as our submersible-style sensor. The durable 5 mil Teflon membrane allows the sensor to perform in the most demanding applications. Modular design lets you easily remove the sensing element for service, reducing maintenance costs.

The sensor's principle of operation is simple. Oxygen diffuses through a Teflon membrane and reduces on the surface of a working electrode, generating a small electrical current proportional to D.O. concentration. An RTD temperature element measures water temperature and corrects the sensor signal for its effect. The result is a D.O. measurement that's accurate over an operating range of 0-50°C.

The Heart of the System.

The Auto-Clean monitor's electronic controls make operation easy, accurate, and reliable:

- LCD display of DO concentration and temperature.
- Dual isolated analog outputs that are assignable to DO and/or temperature.
- Microprocessor-based electronics, with operator interface through four button keypad on the front panel.
- A security code to protect calibration and control settings from unauthorized tampering.
- Contact outputs that include two programmable control relays with variable deadband and time delay functions.
- One relay is used to control the Auto-Cleaner, the other can be configured for either control or alarm mode.
- Internal compressor provides high pressure air for cleaning system.

System Installation.

The installation of an Auto-Clean DO system is quick and simple. A special mounting adapter connects the sensor to standard 1" conduit or pipe, and another adapter provides secure connection of the pipe to a standard handrail system.

The NEMA 4X monitor and cleaner package may be wall mounted or connected to a standard handrail using vertical supports supplied as part of a handrail mounting kit. If desired, the DO monitor may be located up to 1,000 feet away from the cleaning system, which is always located within 50 feet of the sensor.

Replaceable sensing module

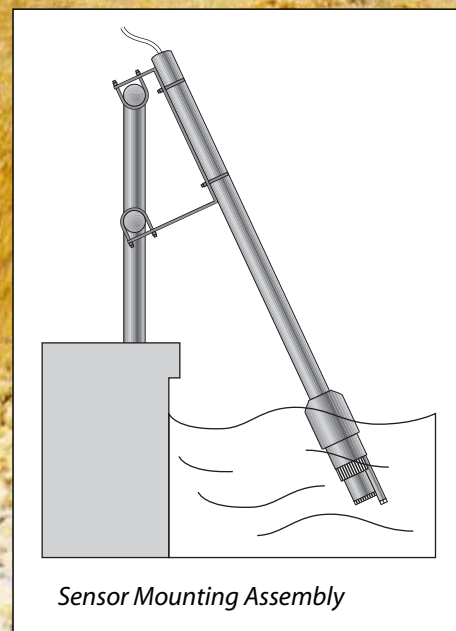

Rebuildable Cartridge Design

The sensor is constructed with a Teflon membrane that is used to isolate the electrochemical cell from the process. Oxygen that is dissolved in the process diffuses through the membrane and is reduced on the surface of the working electrode. The standard sensor uses a membrane with a 5 mil thickness to resist abrasion and tears in high solids applications. For processes that run at lower oxygen concentrations, or require a faster response time, a 2 mil membrane is optional.

The electrochemical components of the sensor are contained in an easily removable cartridge. This modular design makes sensor maintenance fast and easy as the cartridge is easily regenerated by replacing the membrane and electrolyte. This saves you money because you don't have to throw the cartridge away each time you regenerate the sensor. To further reduce your costs and frustration, every sensor comes with 10 replacement membranes and electrolyte, so now you don't have to wait for replacement cartridges.

Multiple Power Sources.

The Q45H is designed for exceptional flexibility to meet a variety of monitoring applications. In its simplest form, the unit is a loop-powered transmitter operating from standard 24 VDC power supplies. This means easy integration into many DCS, PLC, and SCADA systems. Loop-powered instruments include the PID output function.

For applications where a second analog output is desired or where alarm relay functions are needed, an AC powered system is available. Operation from AC power allows the user to utilize analog outputs for independent PID and temperature, or simply dissolved oxygen and temperature. The AC powered system also includes 2 electromechanical relays that can be configured for control, alarm, or timer modes.

For even greater versatility, a portable unit operating from a standard 9V battery is also available. This instrument can be supplied with an internal data logger, making it ideal for short term monitoring at remote sites. The unit will run for 10 days on a single battery, and the data logger will store up to 32,000 data points, easily enough for 10 days of data at 1 minute intervals.



Portable DO monitor

Model Q45D Dissolved Oxygen Monitor Specifications

Electronic Monitor

Display Range:	0 - 40.00 PPM
Accuracy:	0.2% of span or better
Repeatability:	0.05% of span or better
Linearity:	0.1% of span or better
Temp. Drift:	0.01% of span/°C
Display:	Large 4 digit main display, 0.75" characters; 12 digit alpha-numeric second line display
Power:	16-35 VDC for loop-powered unit 115/230 VAC, 50/60 Hz., 10 VA max.; 9-Volt battery for battery operated portable
Control Relays:	Two SPDT relays, 6A @ 250 VAC, 5A @ 24 VDC, resistive
Relay Mode:	Programmable for control, alarm, or timer function
Analog Outputs:	Isolated 4-20 mA, 550 ohm max. load. Two assignable 4-20 mA outputs, 550 ohm max. (AC only)
Data Logger:	Battery version only, stores 32,000 data points
Operating Conditions:	-20-60°C., 0-95% R.H. non-condensing
Enclosure:	NEMA 4X (IP-66) polycarbonate wall, panel, or pipe mount
Weight:	5 lbs. (2.3 Kg.) - standard system 15 lbs. (6.9 Kg.) - Auto-Clean

Sensor

Sensor:	Membrane-covered galvanic sensor
Wetted Materials:	Noryl and 316 Stainless Steel
Sensor Cable:	30 feet (9.0 M) standard, 1,000 feet (300 M) maximum
Response Time:	90% in 60 seconds (2 mil membrane); 90% in 180 seconds (5 mil membrane)
Temperature Limits:	0-50° C.

Ordering Information: Model Q45D-A-B-C-D Dissolved O₂ Monitor

Suffix A - Power

- 1 - 24 VDC, 2-Wire (Single output only)
- 2 - 115 VAC with 2 relays
- 3 - 230 VAC with 2 relays
- 4 - Battery operated with two 0-2.5 VDC outputs
- 5 - Battery operated with internal data-logger
- 6 - 115 VAC Auto-Cleaner (requires option 3 or 4 in Suffix B)
- 7 - 230 VAC Auto-Cleaner (requires option 3 or 4 in Suffix B)

Suffix B - Sensor Type

- 1 - Submersible sensor with 15' cable
- 2 - Submersible sensor with 30' cable
- 3 - Auto-Clean sensor with air nozzle and 30 ft. cable
- 4 - Auto-Clean sensor with air nozzle and 60 ft. cable
- 5 - Flow type (note 6)

Suffix C - Membrane Type

- 1 - 5 mil (standard)
- 2 - 2 mil

Suffix D - Enclosure Heater (for Auto-Clean Systems only)

- 1 - No heater
- 2 - Heater/thermostat (for ambient temperature <10°F)

Options:

- 00-0628 Submersible sensor mounting bracket kit
- 07-0100 NEMA 4X junction box
- 31-0001 Sensor interconnect cable (max. 1000 ft.)
- 07-0215 Handrail mounting hardware
- 00-0624 Mounting bracket kit for auto-clean sensor
- 45-0043 Pipe adapter for Auto-Clean sensor
- 47-0005 2" U-bolt, 304SS
- 05-0068 Panel mount bracket kit
- 00-0633 Low volume flow cell
- 00-0625 1-1/2" flow tee (PVC)

Notes

1. All systems are supplied with one package of membranes, one 120 cc bottle of electrolyte, and one spare parts kit containing 3 each of all o-rings and special screws.
2. AC power is required to allow for two 4-20 mA outputs.
3. Suffix B, item 5, sensor can be used in low-volume flowcell (00-0633), 1-1/2" flow tee assembly (00-0625), or constant-head flowcell (00-0043).
4. Pipe mount requires two 2" U-bolts (47-0005).
5. Panel mount requires bracket (05-0068).
6. Specify low volume flow cell or 1-1/2" flow tee.



Represented By:



Analytical Technology, Inc.
6 Iron Bridge Drive
Collegeville, PA 19426
Phone: 610/917-0991 • Toll-Free: 800/959-0299
Fax: 610/917-0992
E-Mail: sales@analyticaltechnology.com

Analytical Technology
33 Stamford St.
Mossley, Ashton-u-Lyne OL5 0LL
Phone: +44 (0) 1457 832800
Fax: +44 (0) 1457 839500
E-Mail: sales@atiuk.com

2-WIRE VERSION (or BATTERY POWERED)

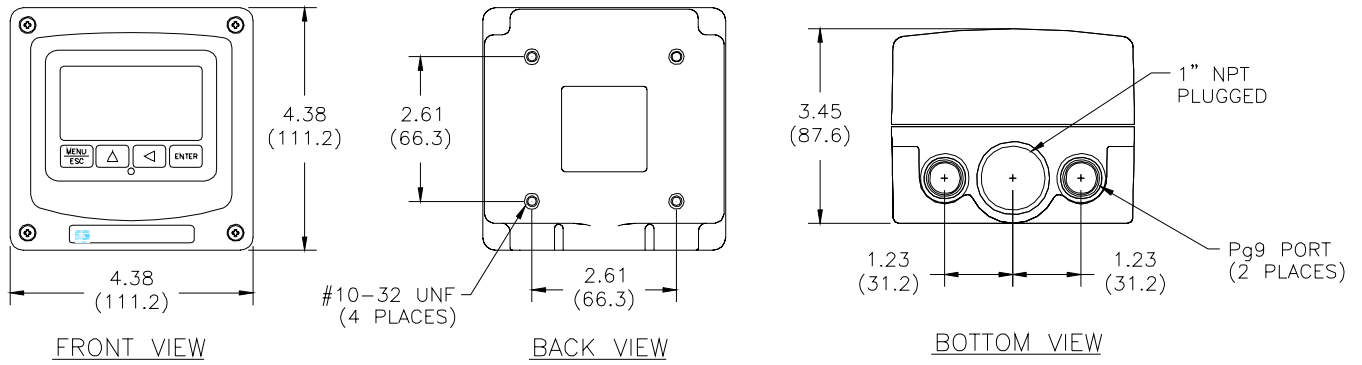

NOTE: JUNCTION BOXES HAVE SAME DIMENSIONS AS 2-WIRE TRANSMITTER

ATI-0655

AC POWERED VERSION

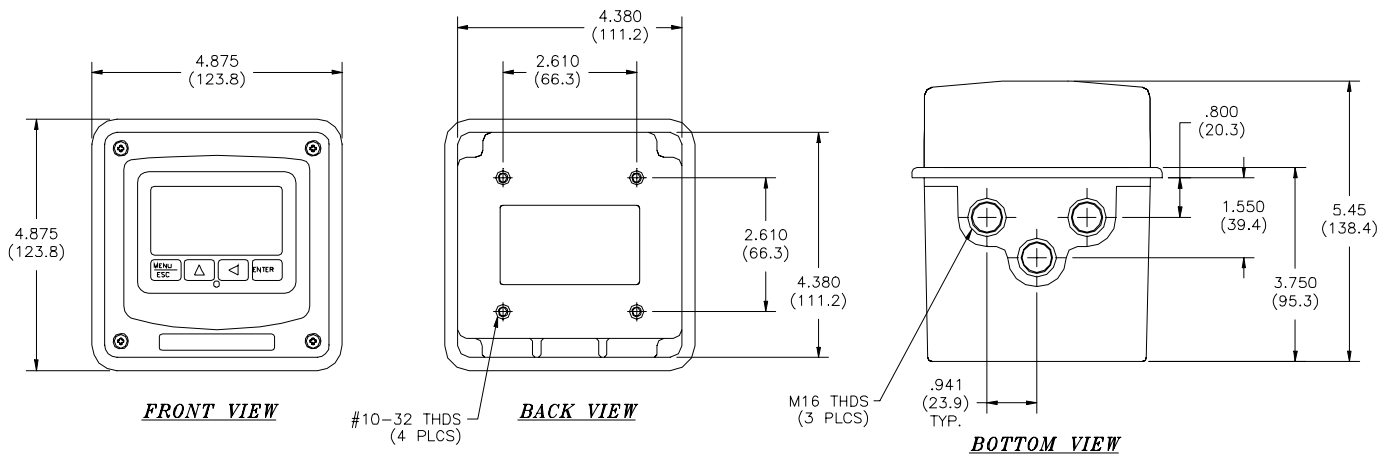

Material: Polycarbonate
 Ratings: Nema 4X (IP-66)
 V-0 Fire Retardant

ATI-0706

WALL MOUNTING

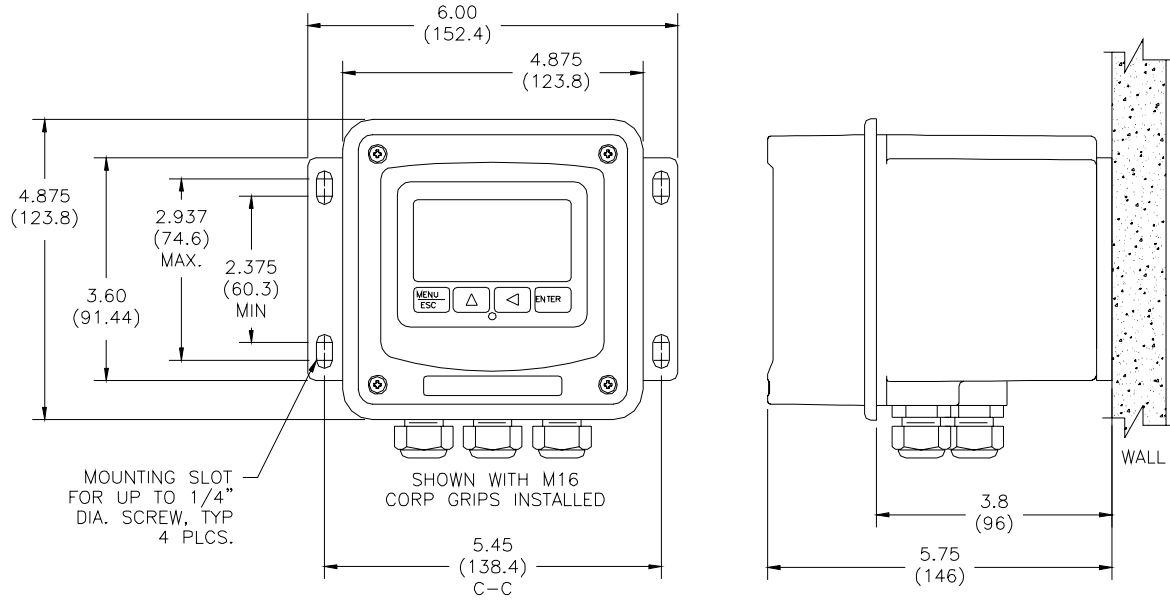

ATI-0709

PIPE MOUNTING

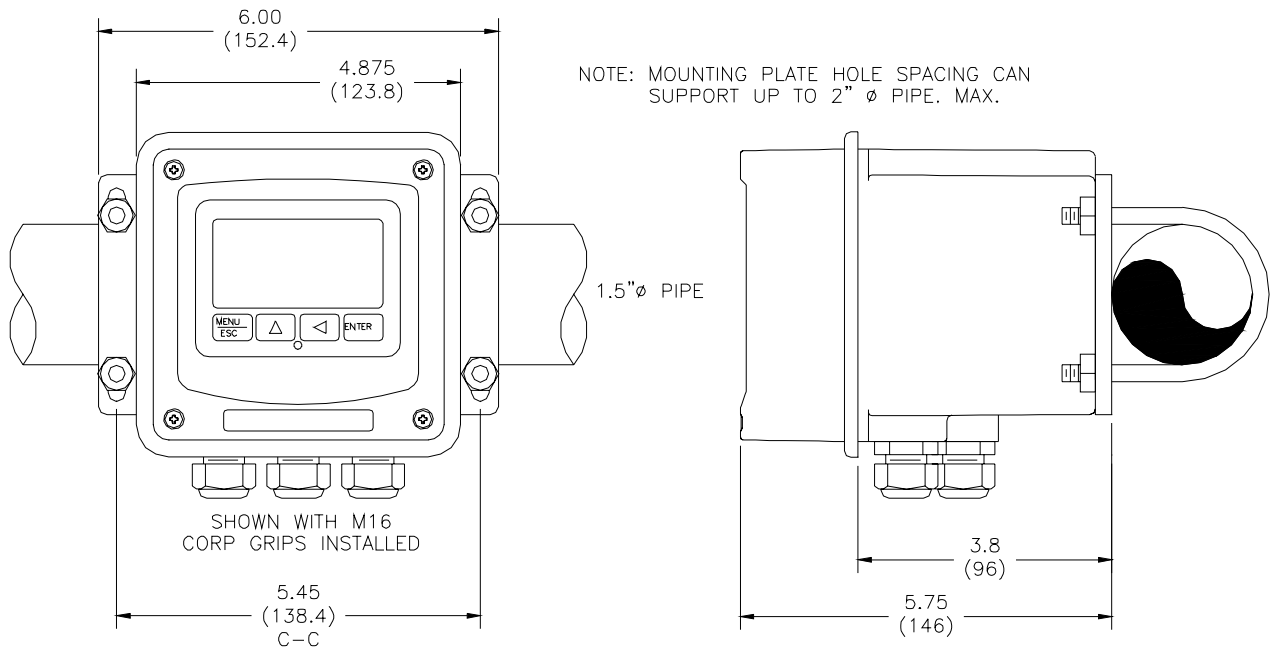

NOTE: PLATE MAY BE TURNED 90° FOR VERTICAL PIPE MOUNTING

ATI-0710

PANEL MOUNTING - AC UNITS

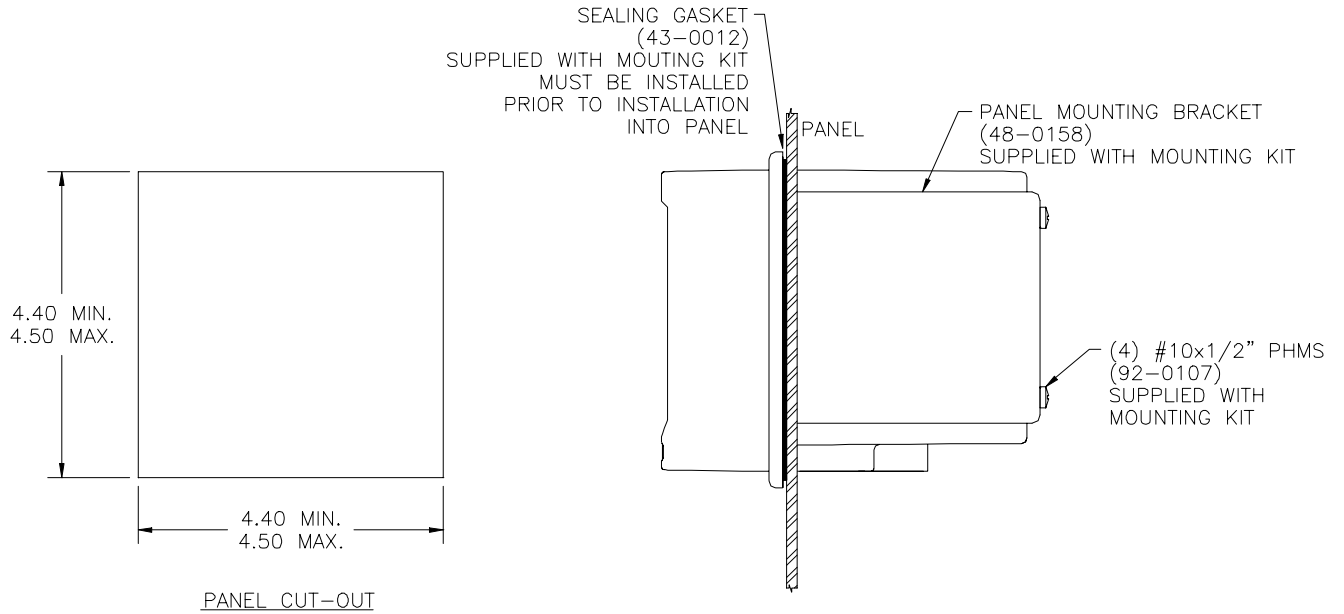

ATI-0711

2-WIRE FLUSH MOUNT

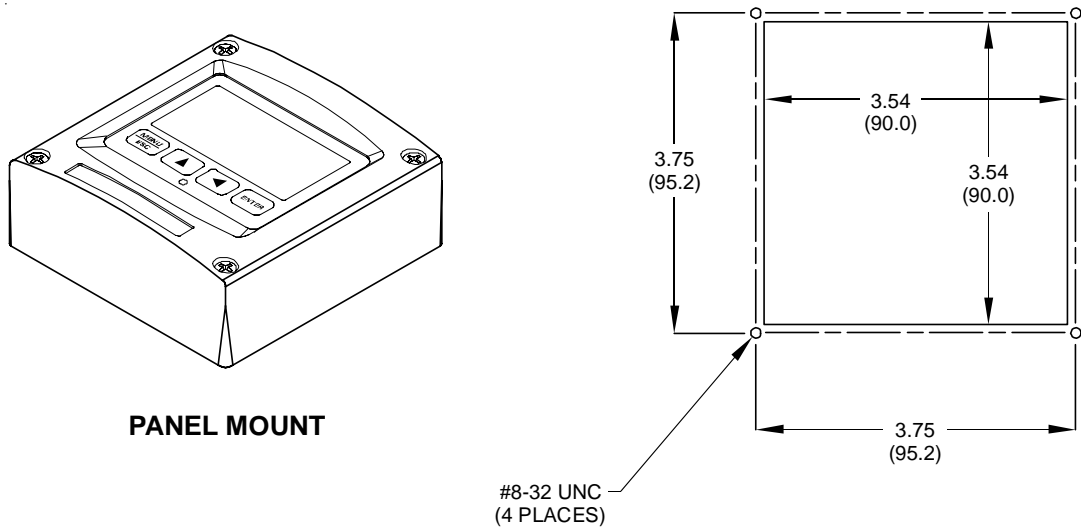

ATI-0611

SUBMERSIBLE SENSOR DIMENSIONS & INSTALLATION

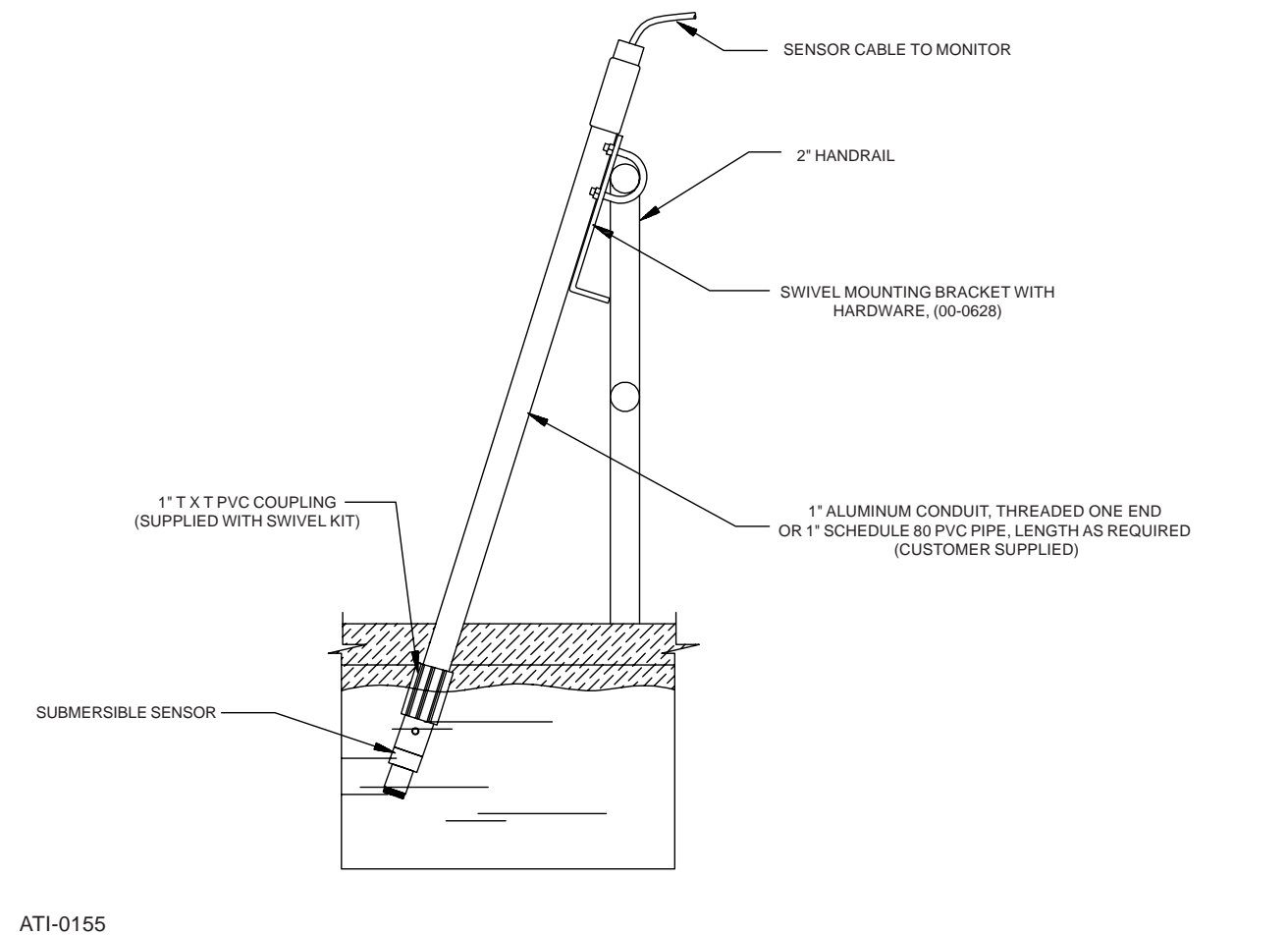
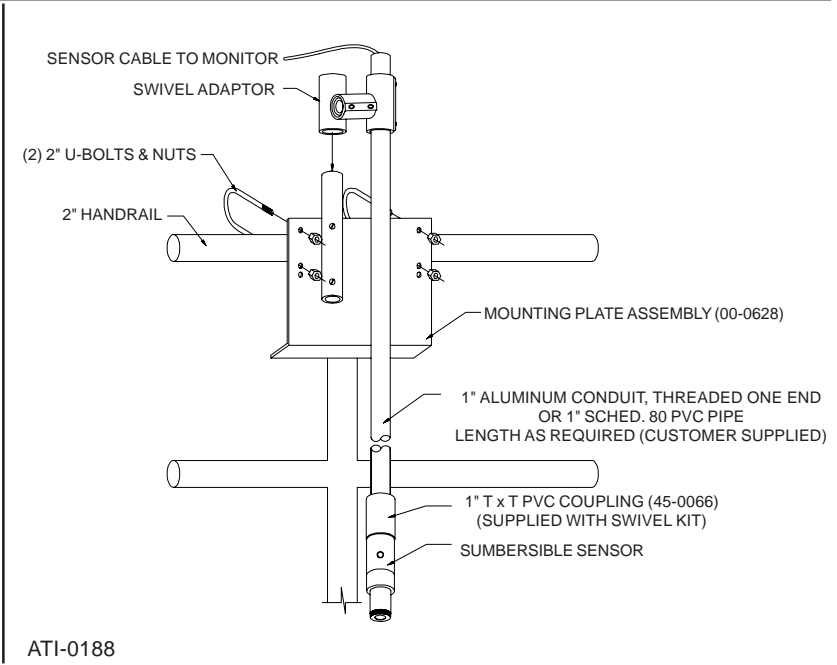
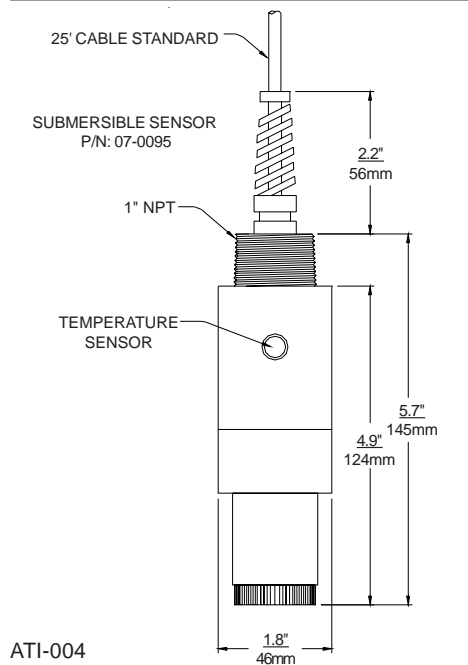

AC POWER, RELAY, AND OUTPUT CONNECTIONS

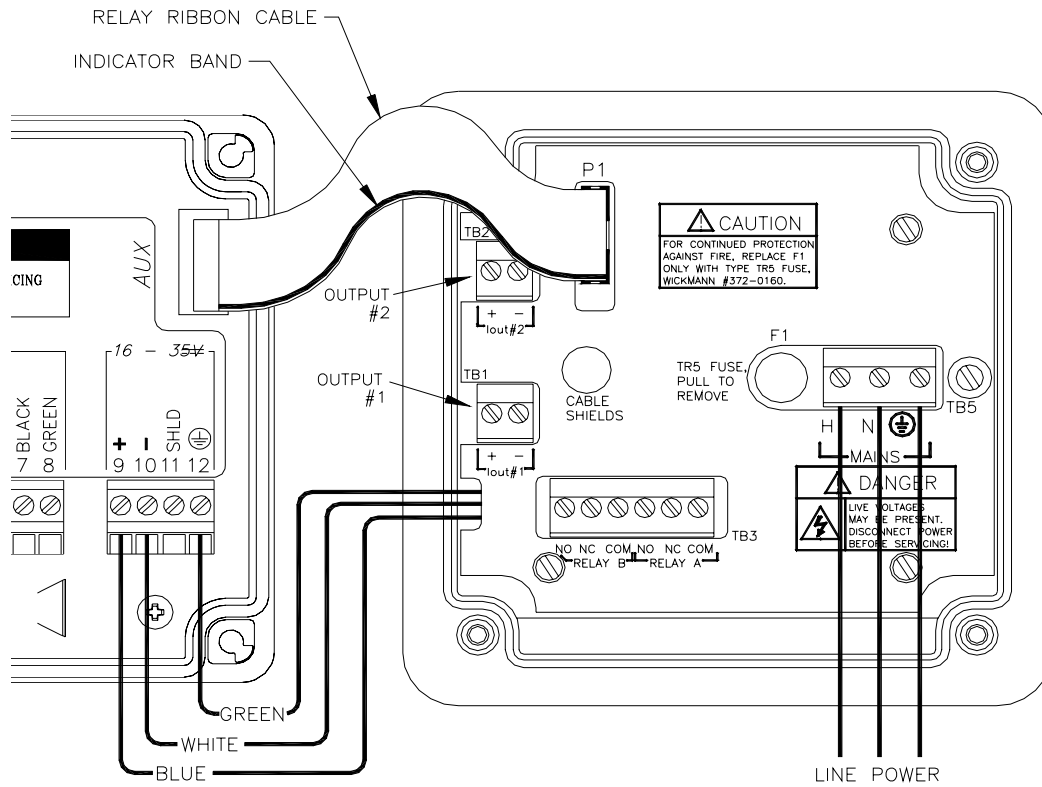

RELAY WIRING TB3 DETAIL

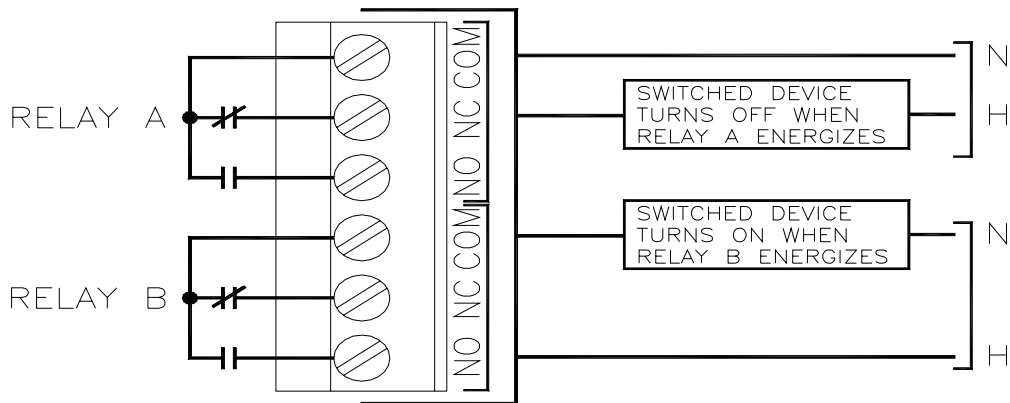

NOTE: DEVICE EXTERNAL WIRING ARE TYPICAL EXAMPLES. RELAY CONTACTS SHOWN IN NORMAL MODE.

ELECTRICAL CONNECTIONS - 2-WIRE TRANSMITTER

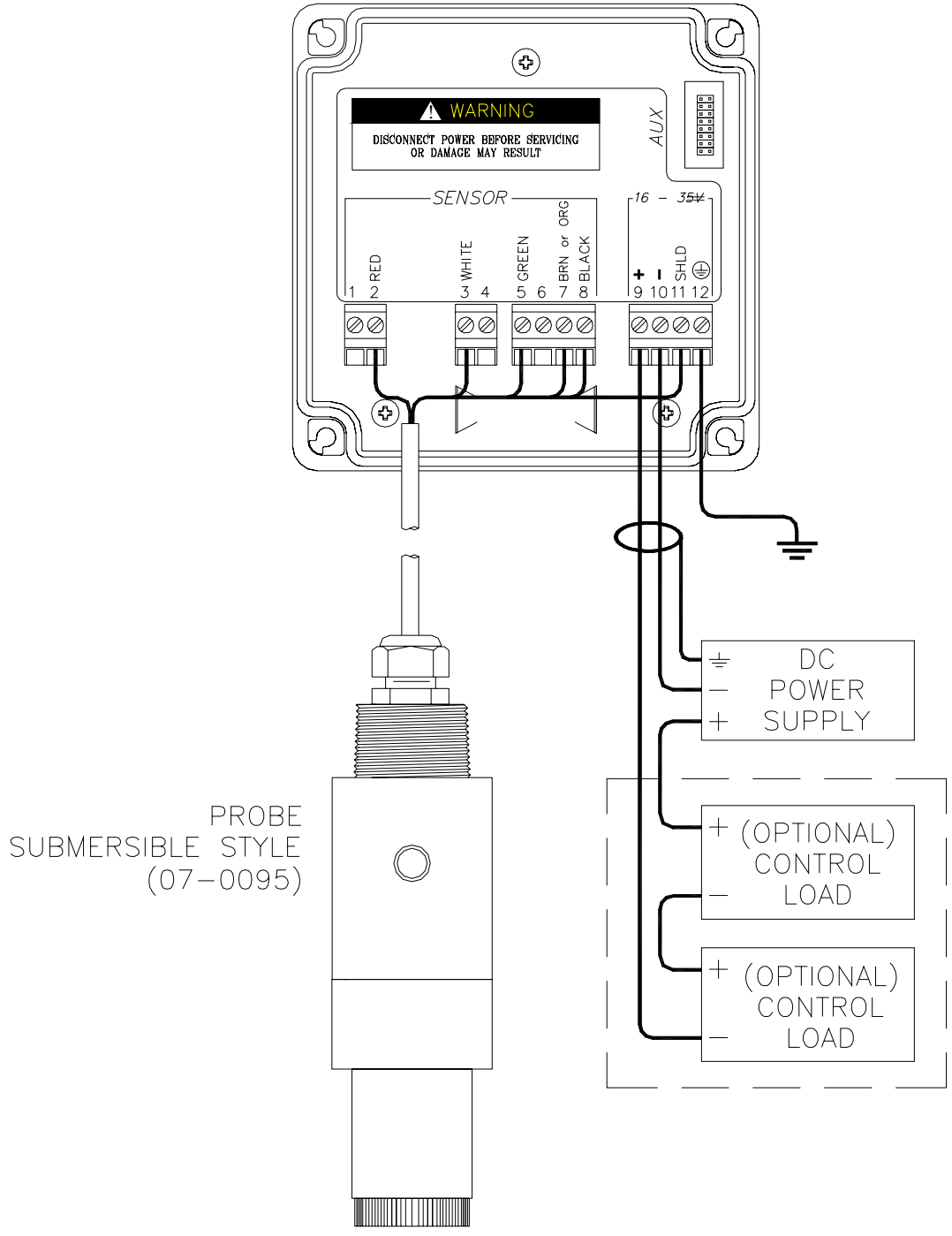

- NOTES:**
1. Voltage between Terminals 9 & 10 **MUST** be between 16 & 35 VDC.
 2. Earth ground into Terminal 12 is **HIGHLY** recommended. This connection can greatly improve stability in electrically noisy environments.

SENSOR CONNECTIONS - REMOTE JUNCTION BOX

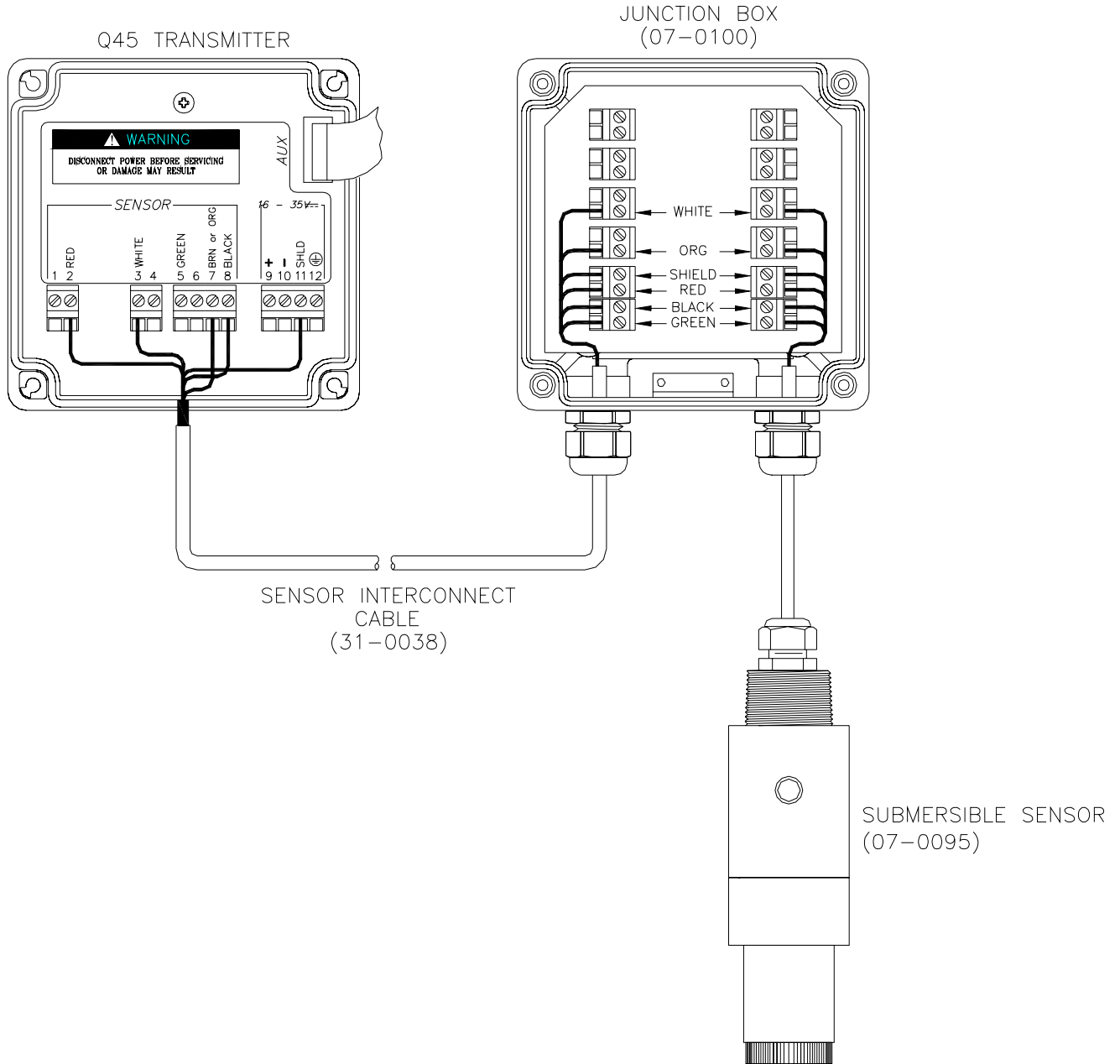

ATI-0717

Q45D/60 AUTO-CLEAN D.O. MONITOR

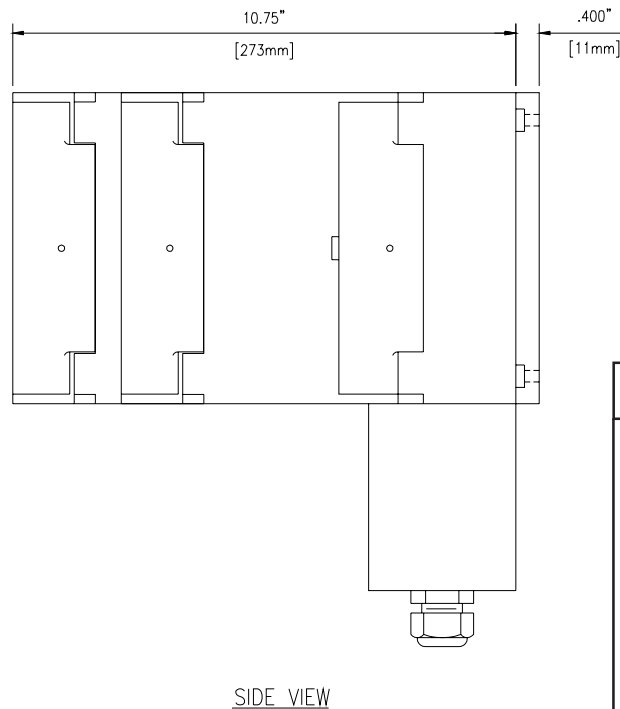
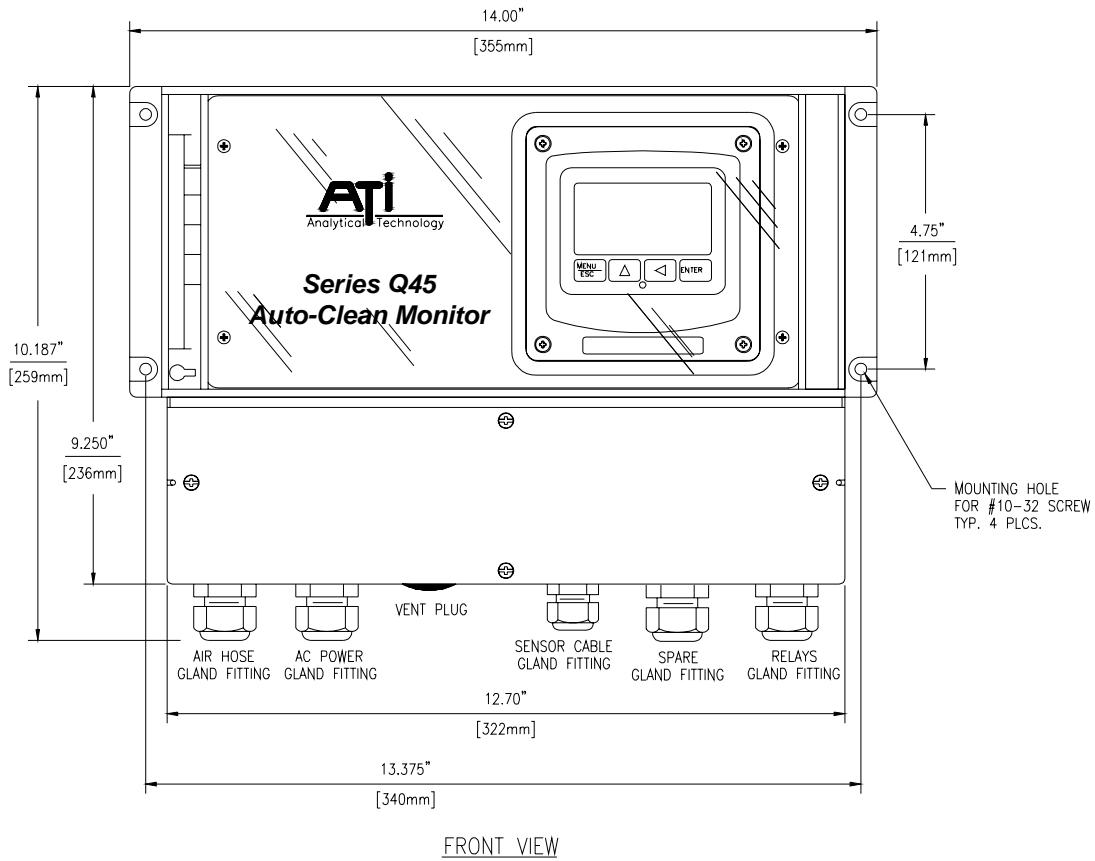

NOTES

- 1) Nema-4X Enclure Material:
Base: Molded ABS, Tan in Color
Cover: Clear Lexan w/Dual Hinge
- 2) Nema-4X Rating:
Nema rated types 4, 4X
IEC 529 rated IP66
- 3) Sensor Material:
Noryl EN265 & Stainless Steel

30' AUTO-CLEAN D.O. SENSOR (07-0097)

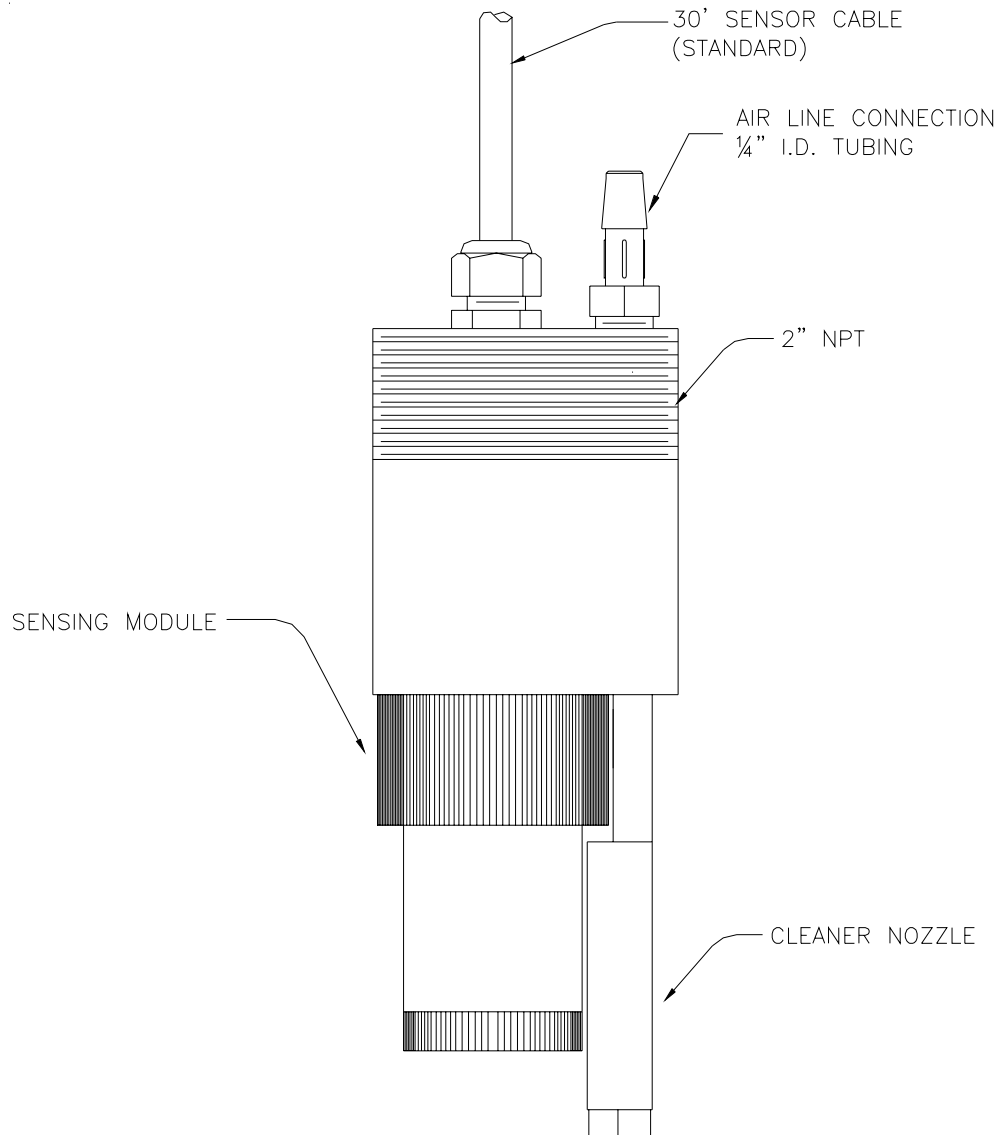

ATI-0679

MONITOR HANDRAIL INSTALLATION

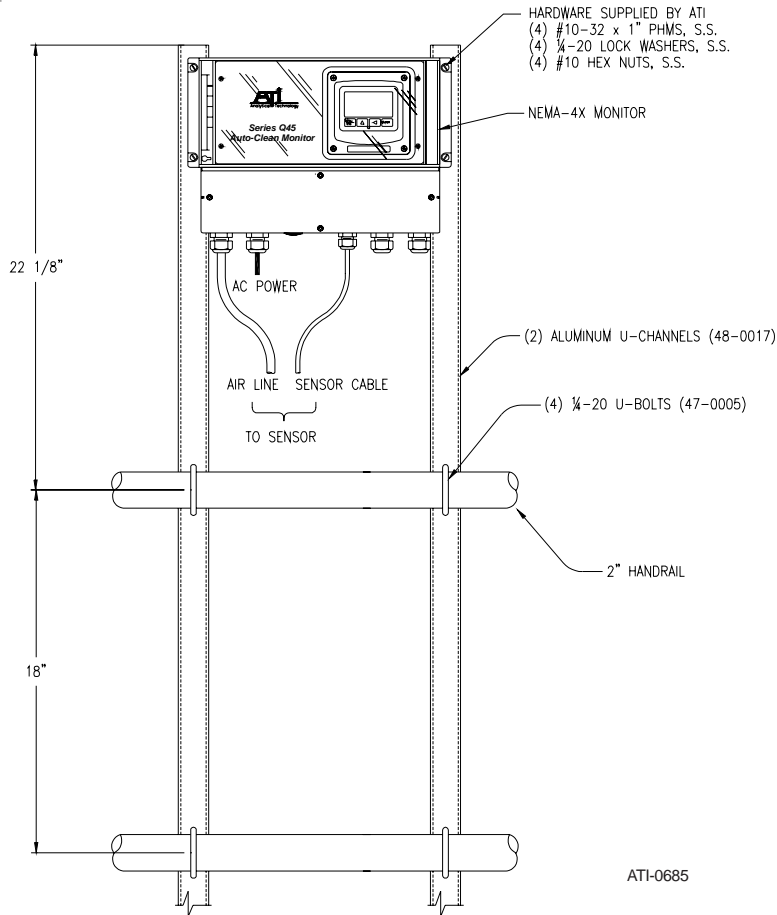

NOTES

- 1) Always mount sensor cleaner within 25 ft. of sensor if possible. Maximum air line distance is 50 ft.
- 2) Sun shade over monitor is recommended in hot climates.
- 3) Monitor Handrail Mounting Kit # 00-0930 supplies all hardware listed for mounting monitor.
- 4) Wall mounting requires customer supplied screws or bolts.
- 5) Sensor Pipe Mounting Kit # 00-0624 supplies mounting plate with hardware and PVC pipe mounting adaptor.
- 6) Sensor Pipe Mounting Kit with Rag Shedder # 00-0629 supplies mounting plate with hardware and PVC rag shedder.

SENSOR HANDRAIL INSTALLATION

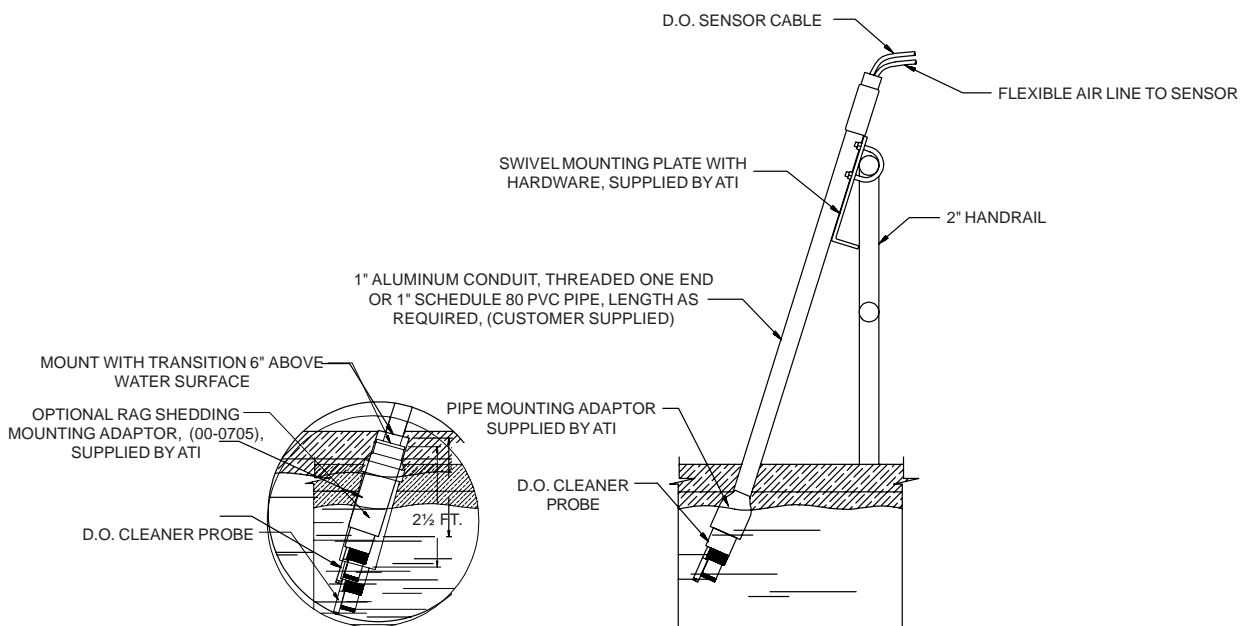

STANDARD SYSTEM WIRING DIAGRAM

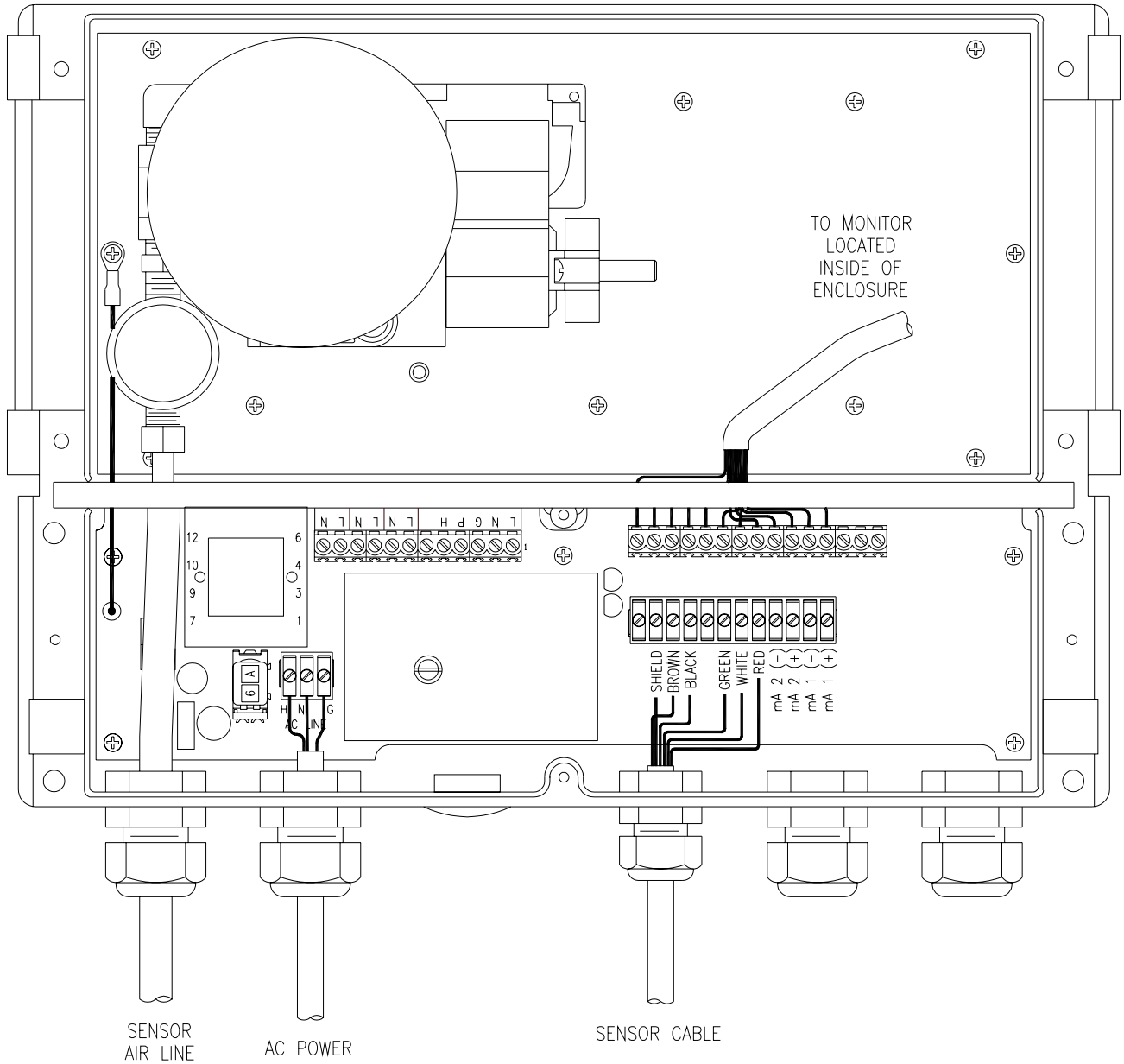

ATI-0723