



JCS-100

Sample Gas Compressor Cooler



JCT
Analysentechnik

Gas Sampling
Probes

Heated Sample
Lines

Sample Gas Coolers

Condensate
Treatment

Accessories

Gas Conditioning
System

Sample Gas
Converters

APPLICATION

- Extractive gas analysis
- Emission and process monitoring
- Continuous drying of sample gas to a precise low and constant outlet dew point
- Minimises water vapour cross sensitivities and volumetric errors

BENEFITS

- High flow rates and high water vapour dew points possible
- Easy to change heat exchangers
- Continuous condensate removal
- Low maintenance operation

FEATURES

- Proven and reliable technology
- Various heat exchanger materials
- One or two independent gas paths
- Digital temperature indication
- Integrated condensate pump
- Status contact with acoustic feedback
- Hot gas bypass compressor technology
- Temperature sensor monitoring
- High current volt free status relay outputs (direct pump switching)
- Long life fan with ball bearing
- Wall mount, optional free stand
- Fully encapsulated temperature sensor
- Small footprint
- Stainless steel housing
- Light weight

TECHNICAL DATA

Description	sample gas compressor coolers
Cooling principle	compressor cooling
Number of heat exchangers / Gas paths	1 or 2
Material heat exchangers	coated aluminum, PVDF, Duran glass, SS316
Operation	
Max. gas flow rate* [NI/hr]	250
Max. gas inlet temperature* [°C]	140
Max. gas inlet dew point* [°C]	80
Gas outlet dew point	3° or 5 °C
Dew point stability (for constant inlet conditions)	±0,2 K
Ambient temperature	5° to 45 °C
Cooling capacity	160 W
Temperature alarm limits	< 0 / > +10 °C
Operating pressure with condensate pump	0,2 to 2,2 bara
Max. operating pressure without condensate pump [bara]	2,5
Ready for operation	< 20 min.
Pressure drop at 100 NI/hr	2 mbar
Construction	
Dimensions over all (W x H x D)	308 x 312 x 375 mm
Installation	stand alone or wall mounting
Mounting position	horizontal
Weight	17 kg
Housing / Colour	stainless steel
Dead volume per gas path	67 ml
Connection sample gas and condensate outlet with condensate pump	PVDF-hose fitting DN 4/6 for SS316 sample gas in/out 4/6mm pipe stubs
Condensate outlet without condensate pump	1/4" NPTi or 3/8" NPTi
Protection class	IP 20 (EN 60529)
Approvals / Signs	CE
Electrics	
Power supply	220 to 240 VAC 50/60 Hz or 100 to 115 VAC 50/60 Hz
Power consumption (depending on load and ambient temperature)	190 VA
Connection power / Status signal	IEC plug
Fusing	6,3 AT in IEC plug
On time	100 %
Temperature indication	digital display
Status threshold	< 0 / > +10 °C
Status delay	0,5 s
Status relay	volt free contact max. 230 VAC / 6 A min. 5 VADC / 5 mA
Connection terminals / Clamping range	spring type terminals 0,5 mm ² to ,5 mm ²

* Results from the effective cooling capacity at 25 °C ambient temperature and 3 °C outlet dew point and can be influenced by further operational parameters

DIMENSIONS

Dimensions in mm

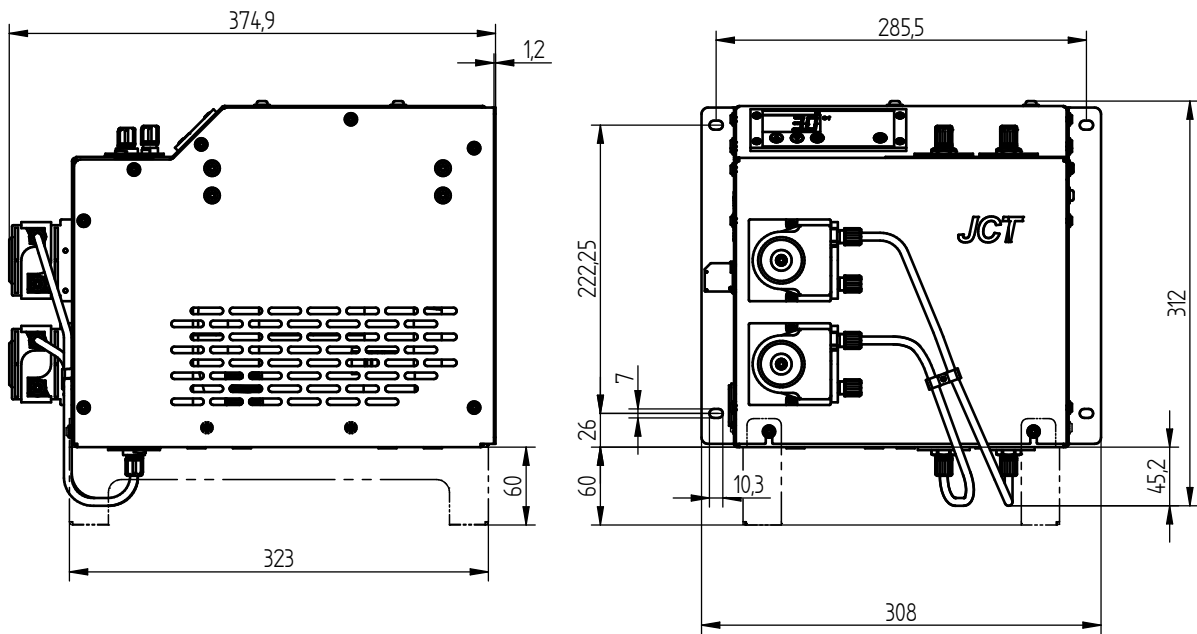

GAS FLOW

1 gas path

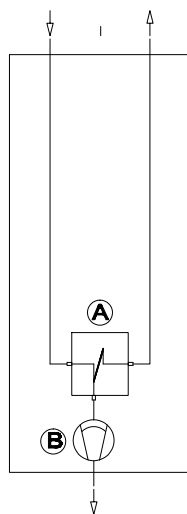

2 gas paths

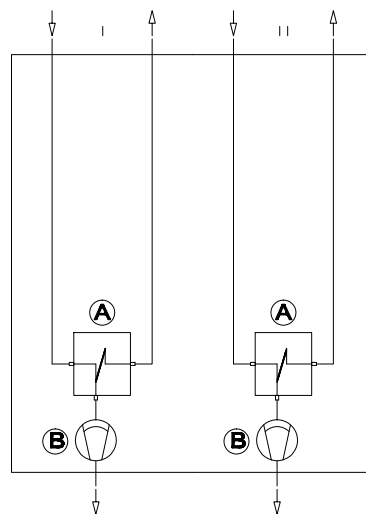

- | | |
|---|--------------------------------|
| A | Actively cooled heat exchanger |
| B | Condensate pump (option) |

ORDER CODE

JCS-100 series

Basic unit	1 heat exchanger / gas path	1.								
	2 heat exchangers / gas paths	2.								
Heat exchanger 1	1st heat exchanger: JHEX-4 aluminum coated		1							
	1st heat exchanger: JHEX-4 PVDF			2						
	1st heat exchanger: JHEX-4 Duran glass				3					
	1st heat exchanger: JHEX-4 SS					4				
Heat exchanger 2	no heat exchanger					0				
	2nd heat exchanger: JHEX-4 aluminum coated						1			
	2nd heat exchanger: JHEX-4 PVDF							2		
	2nd heat exchanger: JHEX-4 Duran glass								3	
	2nd heat exchanger: JHEX-4 SS									4
Condensate pump	1 condensate pump JSR-25									1
	2 condensate pumps JSR-25									2
	without condensate pump JSR-25, 1/4" NPTf outlet									3
	without condensate pump JSR-25, 3/8" NPTf outlet									4
Power supply	230 VAC 50/60 Hz									A
	115 VAC 50/60 Hz									B
Dew point	dew point set up 3°									3
	dew point set up 5°									5
Mounting	without cooler stand									0
	with cooler stand									S

Order code

JCS-10

Gas Sampling **Probes**



Heated Sample **Lines**



Sample Gas **Coolers**



Gas Conditioning **Systems**



NOx **Converter**

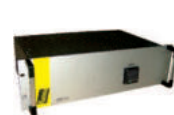

and **solutions** for

